



PORTABLE AIR COMPRESSOR

DIRECT-DRIVE, OIL FREE

OWNER'S MANUAL

and Parts List



For customer service, contact:
1-800-628-8815 ext. 5000
M-F 8:00 AM - 5:00 PM CST.

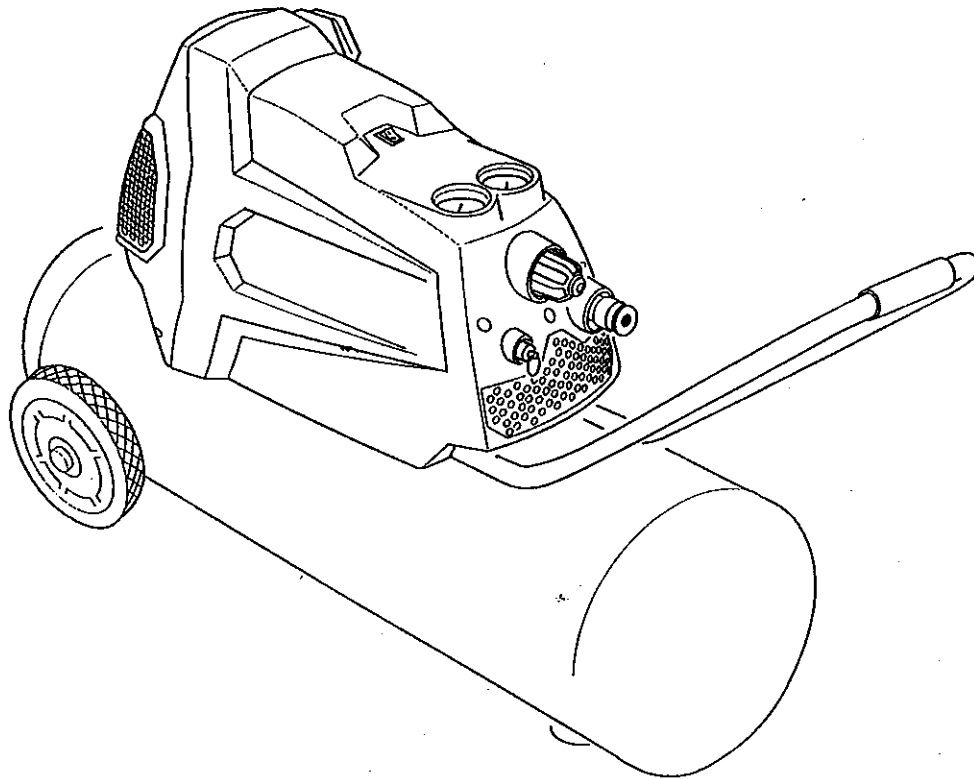

WARNING!

Read and understand all safety precautions and operating instructions before using portable air compressor.

TABLE OF CONTENTS

	Page
Safety Definitions	1
Important Safety Instructions & Guidelines	1
Specifications	2
Glossary	2
Duty Cycle	2
Parts & Features	3
Installation & Assembly	4
Operating Procedures	5
Maintenance	6
Storage	6
Troubleshooting Guide	7
Exploded Parts Diagram	8
Parts List	9
Limited Warranty	10
Español	11



**DO NOT RETURN THIS
PRODUCT TO THE STORE!**
Please call 1-800-628-8815 (ext. 5000)
for any questions regarding this product.
M-F 8:00 AM - 5:00 PM CST.
Thank You

Safety Instructions

The information listed below should be read and understood by the operator. This information is given to protect the user while operating and storing the air compressor. We utilize the symbols below to allow the reader to recognize important information about their safety.



<p align="center">⚠ DANGER</p> <p>Indicates an imminently hazardous situation which, if not avoided, will result in death or serious injury.</p>	<p align="center">⚠ CAUTION</p> <p>Indicates a potentially hazardous situation which, if not avoided, may result in minor or moderate injury.</p>
<p align="center">⚠ WARNING</p> <p>Indicates a potentially hazardous situation which, if not avoided, could result in death or serious injury.</p>	<p align="center">CAUTION</p> <p>When used without the safety alert symbol indicates a potentially hazardous situation which, if not avoided, may result in property damage.</p>





Important Safety Instructions and Guidelines

- Save all instructions

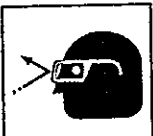
⚠ WARNING

Improper operation or maintenance of this product could result in serious injury and/or property damage. Read and understand all of the warnings and safety instructions provided before using this equipment.

<p align="center">CAUTION</p>	<p>The air compressor should be operated on a dedicated 15 amp circuit. If the circuit does not have 15 free amps available, a larger circuit must be used. Always use more air hose before utilizing extension cords. All extension cords used must be 12 gauge with a maximum length of 25 ft. The circuit fuse type must be a time delay. Low voltage could cause damage to the motor.</p>
<p>Risk of Moving Parts</p> 	<p>If the air compressor is in operation, all guards and covers should be attached or installed correctly. If any guard or cover has been damaged, do not operate the equipment until the proper personnel has correctly repaired the equipment. The power cord should be free of any moving parts, twisting and/or crimping while in use and while in storage.</p>
<p>Risk of Burns</p> 	<p>There are surfaces on your air compressor that while in operation and thereafter can cause serious burns if touched. The equipment should be allowed time to cool before any maintenance is attempted. Items such as the compressor pump and the outlet tube are normally hot during and after operation.</p>
<p>Risk of Falling</p> 	<p>Operation of the air compressor should always be in a position that is stable. Never use the air compressor on a rooftop or elevated position that could allow the unit to fall or be tipped over. Use additional air hose for elevated jobs.</p>
<p>Risk from Flying Objects</p> 	<p>Always wear ANSI Z87.1 approved safety glasses with side shields when the air compressor is in use. Turn off the air compressor and drain the air tank before performing any type of maintenance or disassembly of the hoses or fittings. Never point any nozzle or sprayer toward any part of the body or at other people or animals.</p>

<p>Risk to Breathing</p> 	<p>Avoid using the air compressor in confined areas. Always have adequate space (12 inches) on all sides of the air compressor. Also keep children, pets, and others out of the area of operation. This air compressor does not provide breathable air for anyone or any auxiliary breathing device. Spraying material will always need to be in another area away from the air compressor to not allow intake air to damage the air compressor filter.</p>
<p>Risk of Electrical Shock</p> 	<p>Never utilize the air compressor in the rain or wet conditions. Any electrical issues or repairs should be performed by authorized personnel such as an electrician and should comply with all national and local electrical codes. The air compressor should also have the proper three prong grounding plug, correct voltage, and adequate fuse protection.</p>
<p>Risk of Explosion or Fire</p> 	<p>Never operate the compressor near combustible materials, gasoline or solvent vapors. If spraying flammable materials, locate the air compressor at least 20 feet away from the spray area. Never operate the air compressor indoors or in a confined area.</p>
<p>Risk of Bursting</p> 	<p>Always drain the air compressor tank daily or after each use. If the tank develops a leak, then replace the air compressor. Never use the air compressor after a leak has been found or try to make any modifications to the tank. Never modify the air compressor's factory settings which control the tank pressure or any other function.</p>

Specifications

Pump	Oil-free direct drive	Minimum Circuit Requirement	15 Amps
Induction Motor	1.5 HP	Air Tank Capacity	17 Gallons
Bore	2.48 in.	Cut-in Pressure	120 PSI
Stroke	0.87 in.	Cut-out Pressure	150 PSI
Voltage Single Phase	120 VAC	SCFM @ 40 PSI	5.8
		SCFM @ 90 PSI	3.8

Glossary

CFM: Cubic feet per minute.

SCFM: Standard cubic feet per minute; a unit of measure for air delivery.

PSIG: Pounds per square inch gauge; a unit of measure for pressure.

ASME: American Society of Mechanical Engineers.

California Code: Unit may comply with California Code 462 (I) (2)/ (M) (2).

Cut-In Pressure: The air compressor will automatically start to refill the tank when the pressure drops below the prescribed minimum.

Cut-Out Pressure: The point at which the motor stops when the tank has reached maximum air pressure.

Code Certification: Products that bear one or more of the following marks: UL, CUL, ETL, CSA, have been evaluated by OSHA-certified independent safety laboratories and meet the applicable Underwriters Laboratories Standards for Safety.

Duty Cycle

CAUTION

This is a 50% duty cycle air compressor. Do not run the air compressor more than 30 minutes of one hour. Doing so could damage the air compressor.

Parts & Features

See figures below for reference.

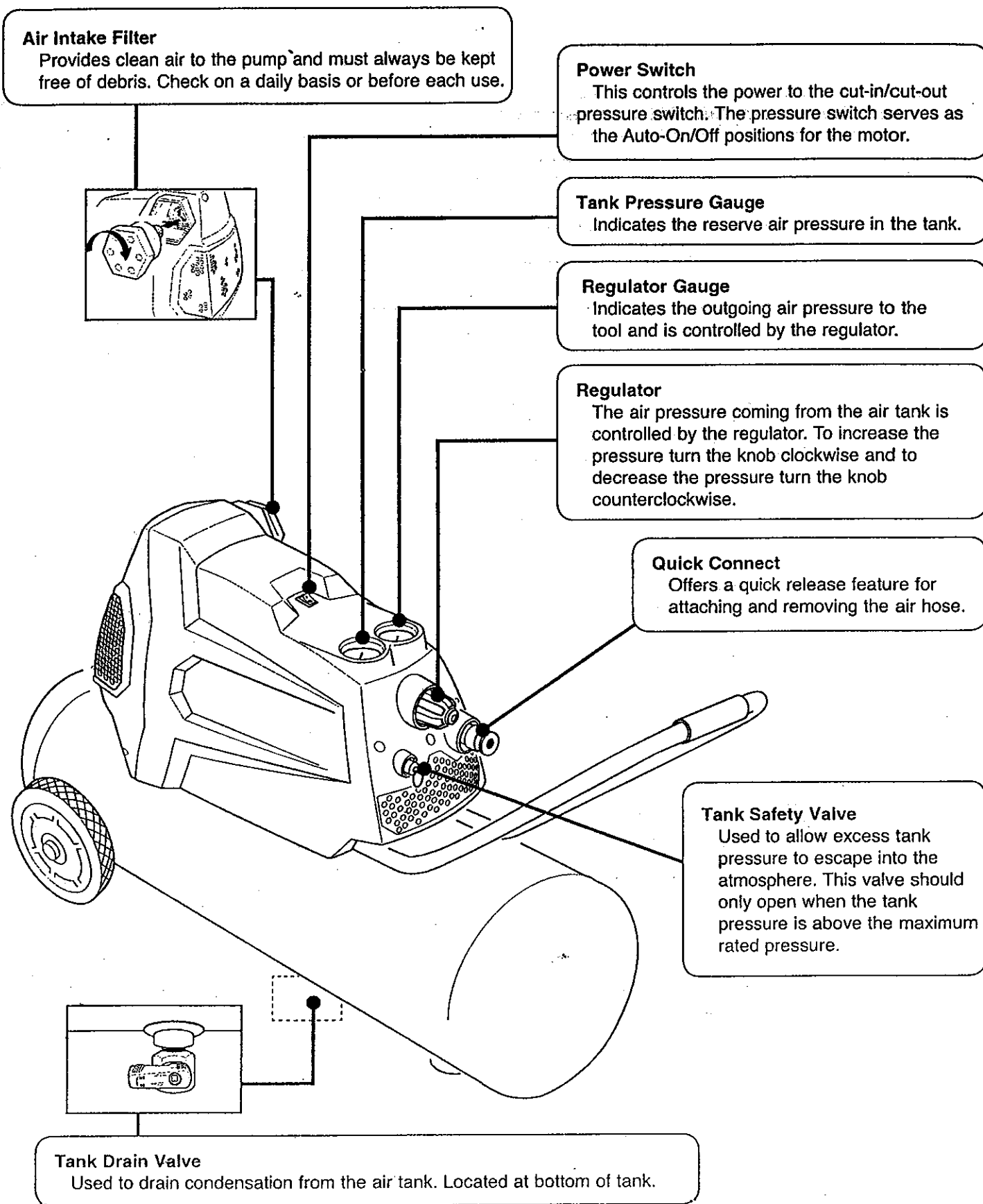

Installation & Assembly

⚠ WARNING

The air compressor should be turned off and unplugged from the power source before any maintenance is performed as well as the air bled from the tank and the unit allowed time to cool. Personal injuries could occur from moving parts, electrical sources, compressed air or hot surfaces. The regulator assembly must be attached before use. Failure to assemble correctly could result in leaks and possible injury. If unsure of assembly instructions or you experience difficulty in the assembly please call customer service for further instruction.

To Install the Air Intake Filter

Remove the air intake filter from the poly bag and thread it onto the head of the compressor as shown. (Fig. 1) Fig. 1

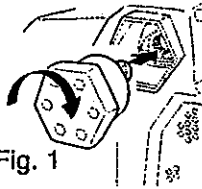

Installing Wheels & Rubber Isolator (Foot)

⚠ WARNING Estimated Assembly Time: 7 min.

The wheels and handle do not provide adequate clearance, stability or support for pulling the unit up and down stairs or steps. The unit must be lifted or pushed up a ramp.

⚠ CAUTION

It may be necessary to brace or support one end of the air compressor when attaching the wheels, because it will have a tendency to tip.

Items Needed For Assembly

- 13 mm or adjustable wrench for hex nut and bolt (Fig. 3)
- 17 mm or adjustable wrench for shoulder bolt (Fig. 2)
- 19 mm or adjustable wrench for nylon lock nut (Fig. 2)

Installing Wheels

Install one shoulder bolt, washer, and one nut for each wheel using bolt holes provided in the wheel bracket. The shoulder bolt will install from the outside of the wheel through the hole in the wheel bracket. Tighten securely with the washer and nut positioned on the inside of the wheel bracket. (Fig. 2)

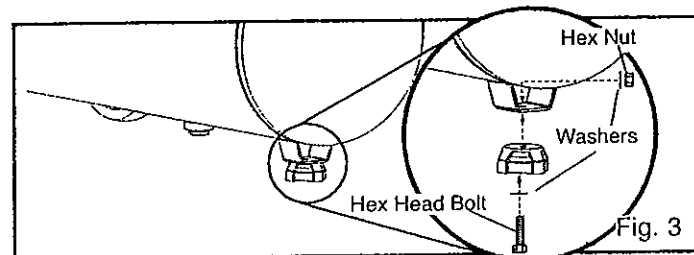
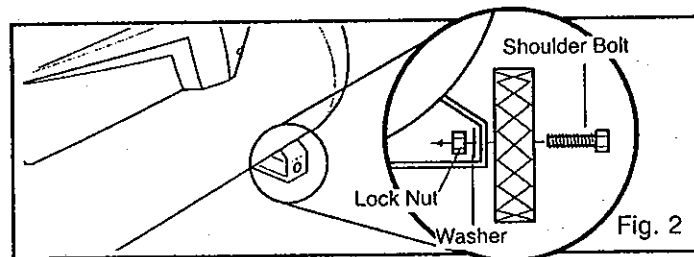

Installing Rubber Isolator (Foot)

Place one M8 x 30 mm hex head bolt and one 8 mm flat washer into the rubber foot with the bolt head and washer inside the recess area. With the rubber foot and washer on the bolt, place the end of the bolt through the hole in the foot bracket on the bottom of the tank. Assemble the 8 mm lockwasher and M8 hex nut. Tighten securely. (Fig. 3)

Location of the Air Compressor

The air compressor should always be located in a clean, dry, and well ventilated environment. The unit should have at minimum, 12 inches of space on each side. The air filter intake should be free of any debris or obstructions. Check the air filter on a daily basis to be sure it is clean and in working order.

Grounding Instructions

This product should be grounded. In the event of an electrical short circuit, grounding reduces the risk of electric shock by providing an escape wire for the electric current. This product is equipped with a cord having a grounding wire with an appropriate grounding plug. (See the figure below.) The plug must be plugged into an outlet that is properly installed and grounded in accordance with all local codes and ordinances. Check with a qualified electrician or service personnel if these instructions are not completely understood or if in doubt as to whether the tool is properly grounded.

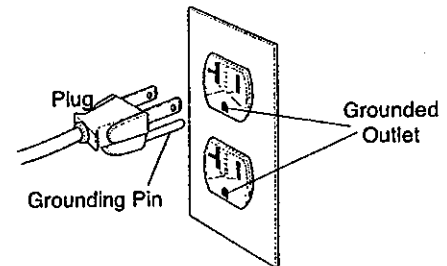

⚠ WARNING

Improper installation of the grounding plug will result in a risk of electric shock. If repair or replacement of the cord or plug is necessary, do not connect the grounding wire to either flat blade terminal. The wire with insulation having an outer surface that is green with or without yellow stripes is the grounding wire. Check with a qualified electrician or serviceman if the grounding instructions are not completely understood, or if in doubt as to whether the product is properly grounded. Do not modify the plug provided; if it will not fit the outlet, have the proper outlet installed by a qualified electrician.

This product is for use on a circuit having a nominal rating of 120 volts and is factory-equipped with a specific electric cord and plug to permit connection to a proper electric circuit. Make sure that the product is connected to an outlet having the same configuration as the plug. No adapter should be used with this product. If the product must be reconnected for use on a different type of electric circuit, qualified service personnel should make the reconnection.

Installation & Assembly

Extension Cords

Use only a 3-wire extension cord that has a 3-blade grounding plug, and a 3-slot receptacle that will accept the plug on the product. Make sure your extension cord is in good condition. When using an extension cord, be sure to use one heavy enough to carry the current your product will draw. Cords must not exceed 25 feet and No. 12 AWG size must be used. An undersized cord will cause a drop in line voltage resulting in loss of power and overheating.

Break-In Procedures

No break-in procedure is required by the user. This product is factory tested to ensure proper operation and performance.

Operating Procedures

Daily Start-Up Procedures

1. Set the Power Switch to the Off position.
2. Check the air compressor visually for any damage or obstruction.
3. Close the drain valve.
4. Connect the air hose to the quick connect socket on the regulator assembly by inserting the quick connect plug on the air hose into the quick connect socket. The quick connect socket collar will snap forward and lock the plug into place providing an air tight seal between the socket and plug. To release the air hose push the collar back on the quick connect socket.
5. Plug the power cord into the proper receptacle.
6. Turn the Power Switch to the On-Auto position and the compressor will start and build air pressure in the tank to cut-out pressure and then shut off automatically.

7. Adjust the regulator to a PSI setting that is needed for your application and be sure it is within the safety standards required to perform the task. If using a pneumatic tool, the manufacturer should have recommendations in the manual for that particular tool on operating PSI settings.

NOTE: The air compressor is now ready for use. The following inflation and cleaning accessories packaged with this unit should only be operated at maximum pressure of 20-30 PSI: blow gun, tapered nozzle, inflation needles, blow gun adapter. Wait at least 5 seconds after stopping compressor motor before turning power back on.

NOTE: Always wear ANSI Z87.1 approved safety glasses with side shields when the air compressor is in use. Never point any nozzle or sprayer toward any part of the body or at other people or animals. Always wear the proper hearing protection.

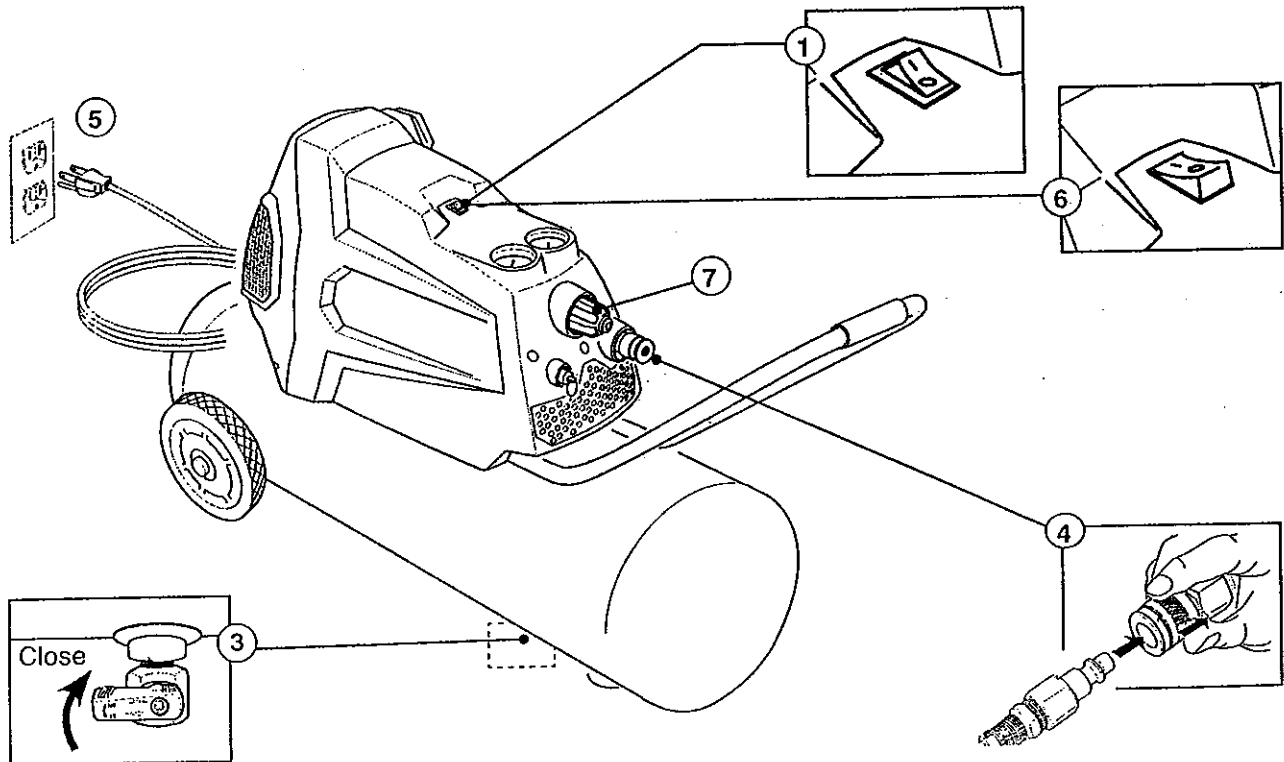

Daily Shut-Down Procedures

1. Set the Power Switch to the Off position.
2. Unplug the power cord from the receptacle.
3. Set the outlet pressure to zero on the regulator.
4. Remove any air tools or accessories. When draining the tank, always use ear and eye protection. Drain the tank in a suitable location; condensation will be present in most cases of draining.
5. Open the drain valve allowing air to bleed from the tank. After all of the air has bled from the tank, close the drain valve to prevent debris buildup in the valve.

⚠ CAUTION

When draining the tank, always use ear and eye protection. Drain the tank in a suitable location; condensation will be present in most cases of draining.

⚠ WARNING

Water that remains in the tank during storage will corrode and weaken the air tank which could cause the tank to rupture. To avoid serious injury, be sure to drain the tank after each use or daily.

Maintenance

NOTE: Any service procedure not covered in the maintenance schedule below should be performed by qualified service personnel.

⚠ WARNING

The air compressor should be turned off and unplugged from the power source before any maintenance is performed as well as the air bled from the tank and the unit allowed time to cool. Personal injuries could occur from moving parts, electrical sources, compressed air or hot surfaces.

⚠ CAUTION

To ensure efficient operation and longer life of the air compressor unit, a routine maintenance schedule should be followed. The following schedule is geared toward a consumer whose compressor is used in a normal working environment on a daily basis.

Items to Check/Change	Before each use or daily
Check Tank Safety Valve	X
Overall Unit Visual Check	X
Check Air Filter	X
Drain Tank	X

Storage

For storing the air compressor, be sure to do the following:

1. Turn the unit off and unplug the power cord from the receptacle.
2. Remove all air hoses, accessories, and air tools from the air compressor.
3. Open the drain valve to bleed all air from the tank.
4. Close the drain valve.
5. Perform the daily maintenance schedule.
6. Store the air compressor in a clean and dry location.

NOTES

Troubleshooting Guide

⚠ WARNING The air compressor should be turned off and unplugged from the power source before any maintenance is performed as well as the air bled from the tank and the unit allowed time to cool. Personal injuries could occur from moving parts, electrical sources, compressed air, or hot surfaces.

PROBLEM	POSSIBLE CORRECTION
Air leaks at the check valve or at the pressure relief valve.	A defective check valve results in a constant air leak at the pressure relief valve when there is pressure in the tank and the compressor is shut off. Drain the tank, then remove and clean or replace the check valve.
Air leaks between head and cylinder.	Be sure of proper torque on head bolts. If leak remains, contact customer service or technician.
Air leak from safety valve.	Operate the safety valve manually by pulling on the ring. If the valve continues to leak when in the closed position, it should be replaced.
Pressure reading on the regulated pressure gauge drops when an accessory is used.	<p>If there is an excessive amount of pressure drop when the accessory is used, replace the regulator.</p> <p>NOTE: Adjust the regulated pressure under flow conditions (while accessory is being used). It is normal for the gauge to show minimal pressure loss during initial use of the tool.</p>
Excessive tank pressure.	Move the Power Switch to the Off position. If the unit doesn't shut off, unplug it from the power source and contact customer service or technician.
Motor will not start.	<p>Make sure power cord is plugged in and the switch is on. Inspect for the proper size fuse in your circuit box. If the fuse was tripped, reset it and restart the unit. If repeated tripping occurs, replace the check valve or contact customer service or technician.</p> <p>NOTE: To reset the motor overload turn ON/OFF switch OFF and wait 10 minutes (minimum). Restart unit.</p>
Excessive moisture in the discharge air.	<p>Remove the water in the tank by draining after each use. High humidity environments will cause excessive condensation. Utilize water filters on your air line.</p> <p>NOTE: Water condensation is not caused by compressor malfunction. Be sure the compressor's air output is greater than your tool's air consumption rate.</p>
Air leaks from the tank body or tank welds.	Never drill into, weld or otherwise modify the air tank or it will weaken. The tank can rupture or explode. Compressor cannot be repaired. Discontinue use of the air compressor.

Air Compressor Item # 236005 / Model # F217HKL

Parts List

Ref. #	Kit #	Part Number	Description	Quantity	Ref. #	Kit #	Part Number	Description	Quantity
1		E101727	Fitting- Elbow 3/8 NPT x 3/8 Comp.	1	39		E101805	Isolator Foot, Kobalt	1
2	2		Screw- SH, M6 x 1 x 35 mm	5	40			Flat Washer, 8 mm	9
3			Lockwasher, 6 mm	7	41			Bolt- Hex Head, M8 x 1.25 x 30 mm	1
4	1		Housing- Intake Filter	1	42			Lockwasher, 8 mm	9
5	1	E101613	Element, Foam, Air Intake Filter	1	43			Hex Nut M8 x 1.25	5
6	1		Cover- Intake Filter	1	44			Tank Weldment- Painted	1
7		E100284	Cylinder- Head	1	45		E101800	Strain Relief (HEYCO Type)	1
8	4		Gasket- Head	1	46	2		Lockwasher, 5 mm	1
9	4		Screw- M3 x 4.5 mm	2	47		E101610	Check Valve w/.35 mm Orifice	1
10	4		Valve Plate	1	48		E101809	Tube w/ Fittings	1
11	4		Valve- Inlet	1	49			Motor Assembly, 1.5 HP	1
12	4		Valve Plate Retainer	1	50		E101808	Hose-Tank-to-Manifold	1
13	4		Valve- Outlet	1	51		E101729	Safety Valve, 165 PSI	1
14	4		Plate- Outlet Retainer	1	52		E101528	Shroud- Front, Kobalt	1
15	4		Gasket- Cylinder	1	53		E101724	Vent- Front, Kobalt	1
16	2		Cylinder	1	54		E100307	Quick Connect Coupler	1
17	2		Eccentric	1	55		E101629	Knob- Regulator, Kobalt	1
18	2		Screw- SH, M5 x 0.8 x 10	1	56			Plug- 1/4" NPT	3
19	2		Hex Nut- M5 x 0.8	1	57		E101811	Manifold w/ Regulator	1
20	2		Connecting Rod (Piston)	1	58		E101733	Pressure Gauges	2
21	2		Piston Seal	1	59		E101713	Pressure Switch- 120-150 PSI	1
22	2		Piston Cap	1	60			Screw- SHC- M8 x 1.25 X 16 mm	4
23	2		Screw- SHCS 5m x 0.8 x 18 mm	1	61		E101790	Power Cord 14/3 (HEYCO Type)	1
24		E100297	Fan- Cooling/Crankcase	1	62		E101795	Switch- On / Off	1
25			Screw- M6 x 1.0 x 16	3	63			Screw- M8 x 1.25 x 20	4
26			Flat Washer, 6 mm	3	64			Screw- Plastite, 4.4 x 1.14 x 15	12
27		E101529	Shroud-Rear, Kobalt	1	65	2		6203ZCS Ball Bearing (Sealed)	1
28		E101725	Vent- Rear, Kobalt	1					
29		E101789	Grip- Handle	1					
30		E101609	Handle	1					
31			Screw- RPH-M4 x 0-7 x 35	3					
32			Screw- M5 x 8 x 20 mm	4					
33	3		Shoulder Bolt (M10 x 1.25)	2					
34	3		Flat Washer- 10 mm	2					
35	3		Wheel- 7" x 1.5" (Kobalt Dmd Trd)	2					
36	3		Hex Nut- M5 x 1.25	2					
37	3		Hubcap- Kobalt Wheel	2					
38		E101717	Drain Valve- 1/4 Turn	1					

NOTE: Any part number field without a number listed is not available. Descriptions are provided for reference only.

Kit numbers, descriptions, and included components are listed below:

Kit #	Part #	Kit Name	Reference #
1	E101611	Air Filter Kit	4, 5, 6
2	E101275	Piston Kit	2, 16-23, 46, 65
3	E101807	Wheel Kit (2 Wheels Incl.)	33-37
4	E101038	Valve Plate Assy Kit	8-15

For replacement parts, please call 1-800-628-8815 ext. 5000.

Limited Warranty

This warranty is limited to manufacturing defects in the compressor for a 36-month period, except for manufacturing defects related to the compressor pump, check valves, pressure switch and electric motor for which the warranty on these "excluded items" shall be for a 12-month period. If at any time during the 36-month period your air compressor fails due to a manufacturing defect take it to an authorized warranty repair center. If the repair center determines the product has failed due to its workmanship it will be repaired at no charge. If the failure is due to normal wear and tear or any malfunction, failure or defect resulting from misuse, abuse, neglect, alterations, modifications or repair by anyone other than an authorized warranty service center the warranty is void.

LIMITED WARRANTY FOR COMMERCIAL USE

This warranty is limited to manufacturing defects. If at any time from the first 90 days of purchase date your air compressor fails due to a manufacturing defect take it to an authorized warranty repair center. If the repair center determines the product has failed due to its workmanship it will be repaired at no charge. If the failure is due to normal wear and tear or any malfunction, failure or defect resulting from misuse, abuse, neglect, alterations, modifications or repair by anyone other than an authorized warranty service center the warranty is void.

PROOF OF PURCHASE REQUIRED

NOTE: All warranty is contingent on the customer providing a valid receipt for proof of purchase. If no receipt is provided, the manufacturer's date code will be used in place of purchase date.

Limited Warranty applies in the U.S. and Canada only and gives you specific legal rights. You may also have other rights that vary from State to State or country to country. To find your authorized warranty service center, please call 1-800-628-8815, ext. 5000.